



ALTEX[®]

SunProject™
line of products

DEKO[®] LITE-LIFT[®] CASSETTE S-100

CHAIN OPERATED ROLLER SYSTEMS

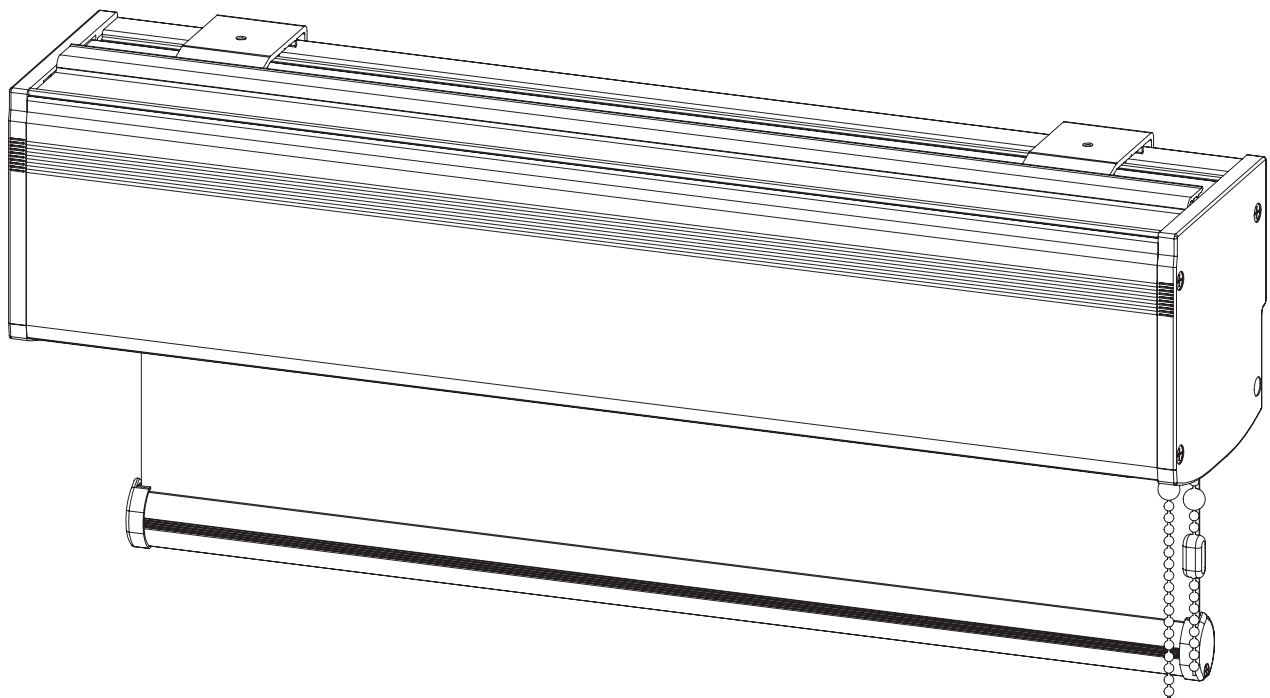

DKO1-LL-S100

CASSETTE S100



ELEVATION

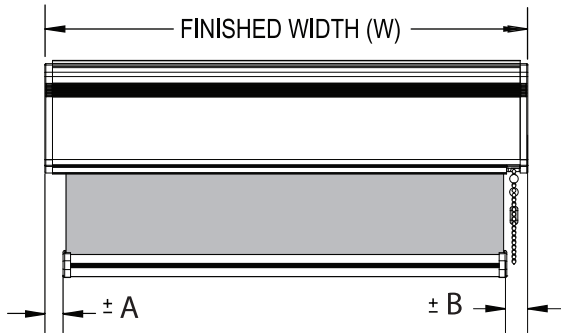

TOLERANCE +/- 1.5mm [0.0625"]
DIMENSIONS mm [inches]

DIMENSION	FABRIC EDGE CLEARANCE [±mm / ±in] BY TUBE TYPE									
	32		38		46		53		63	
A	22	0.875	22	0.875	22	0.875	22	0.875	n/a	n/a
B	25	1.000	25	1.000	25	1.000	25	1.000	n/a	n/a

MOUNTING

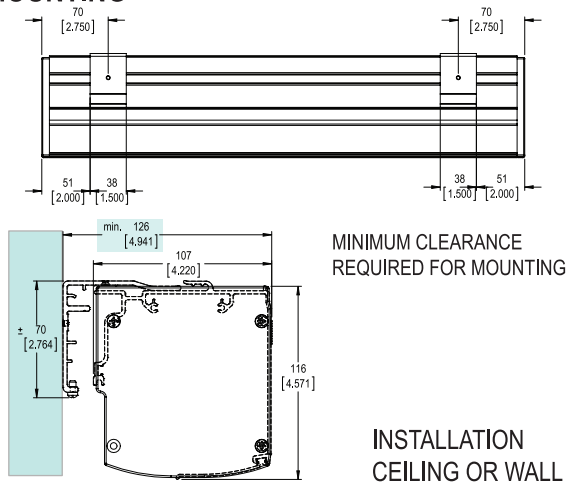

SECTION

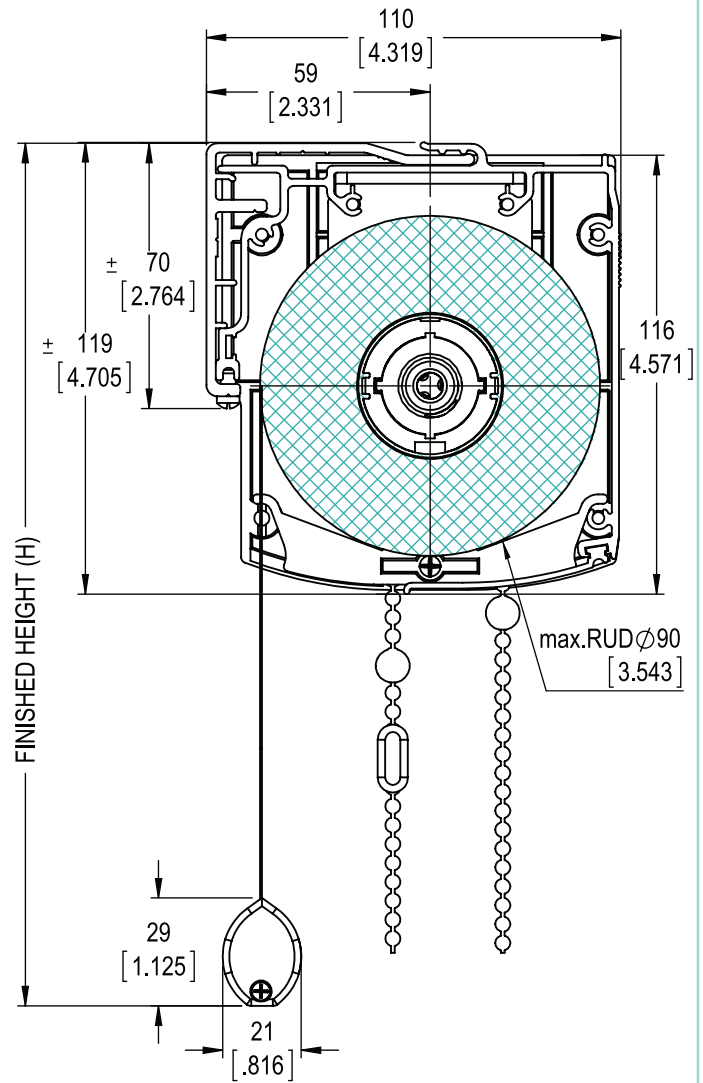

MODEL	DKO-1-LL-S100
--------------	----------------------

ROLL STYLE

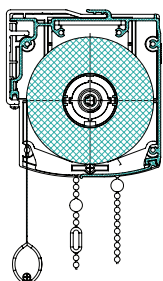

REGULAR ROLL

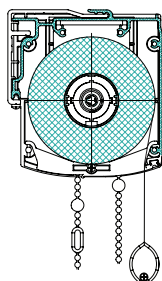

REVERSE ROLL

NOTE: For size limitation guidelines, please refer to our Size Limitation Detail Sheets or contact our Technical Department.

MONTREAL T: 800.363.5930 @: info@altex.ca	TORONTO T: 888.836.6980 @: sales@altex.ca	VANCOUVER T: 888.980.9899 @: servicewest@altex.ca
--	--	--